

## ILLUSTRATION

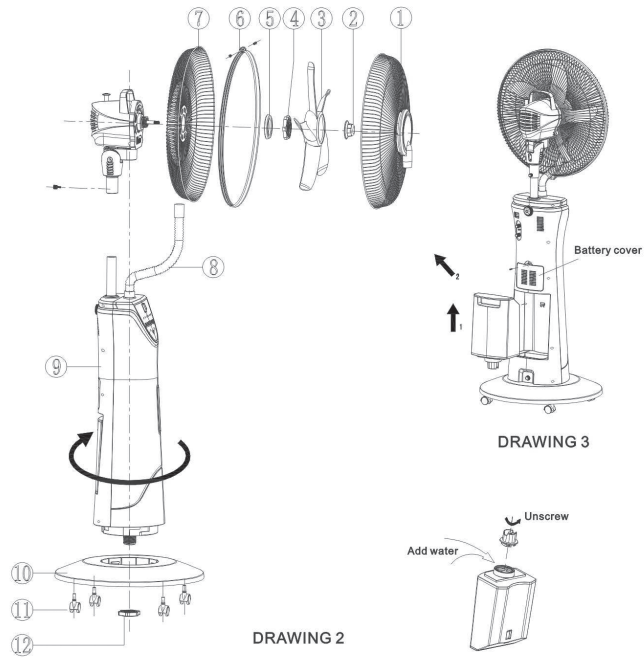

### NAME OF PARTS

- |                |                    |                     |
|----------------|--------------------|---------------------|
| 1. Front grill | 5. Gasket          | 9. Body             |
| 2. Nut         | 6. Hoop            | 10. Base            |
| 3. Blade       | 7. Back grill      | 11. Universal wheel |
| 4. Big nut     | 8. Corrugated pipe | 12. Big nut         |

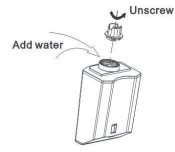

# eurolux

Lighting your way

## Rechargeable Mist Fan

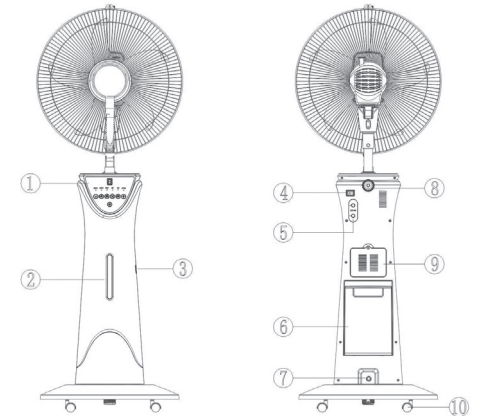

### NAME OF PARTS

- |                   |                |                     |
|-------------------|----------------|---------------------|
| 1. Function panel | 4. Switch      | 7. Water nut        |
| 2. LED            | 5. DC terminal | 8. Adjusting nut    |
| 3. AC Socket      | 6. Water Tank  | 9. Battery cover    |
|                   |                | 10. Universal wheel |

## ENVIRONMENTAL PROTECTION



Waste electrical & Electronic equipment regulations requires that any of our products showing this marking must not be disposed of with other household or commercial waste. To prevent possible harm to the environment or human health from uncontrolled waste disposal, please separate any such products from other waste types and recycle it responsibly at your local facilities.

Please read instructions before commencing installation and retain for future reference.

## IMPORTANT SAFEGUARDS

### F82 - attachments:

If the external flexible cable or cord of this luminaire is damaged, it should be exclusively replaced by the manufacturer or his service agent or a similar qualified person in order to avoid a hazard. To ensure that you get maximum longevity and maximum use out of your luminaire, please observe the following safety instructions.

**⚠** Electrical products can cause death, injury, or damage to property. Installation of the luminaire must be carried out by a qualified electrician, in accordance with SANS 10142. On completion of installation, ensure that the Certificate of Compliance is updated.

- Before connecting the luminaire, ensure that voltage indicated on the rating label Corresponds with the mains voltage in your home.
- This luminaire is checked in full for conformity to the quality standards and safety requirements.
- The manufacturer / supplier is not responsible for any damage of properties and persons, caused by the incorrect use or installation of the luminaire.
- Ensure all items / components, threads and screws are tightly secured.

### IMPORTANT:

- Tampering with this luminaire, will invalidate your warranty.
- Please check whether the connection of the power cord is safe and reliable before installation.
- Always ensure that the mains supply voltage is correct.
- Choking hazard: May contain small parts. Keep away from children.
- Do not insert your fingers or any part of your body into the electrical contact and sockets of this product whilst it is connected to the electrical supply.
- Item may vary slightly from the picture on the carton.

## SPECIFICATIONS

- **Light source:** 10pc Integrated LED
- **Battery:** 12V 4.5Ah rechargeable lead-acid Battery
- **Charge time:** 12-15 hours
- **Fan Duration:**
  - 2 hours / Fan high speed
  - 5.5 hours / Fan medium speed
  - 28 hours / Fan low speed
- **Mist Duration:**
  - 1.5 hours / Mist high
  - 2.5 hours / Mist medium
  - 4 hours / Mist low
- **Light Duration:**
  - 35 hours / Bright
  - 85 hours / Dim
- **Water Tank Capacity:** 2 Litres
- **Dimension:** 400mm x 421mm x 1165mm
- **Voltage:** 220-240V 50Hz

## OPERATION

### IMPORTANT:

- Please read this manual carefully before you start using this luminaire in full charge.
- Make sure that the voltage is correct before plug-in.
- Charge the luminaire when light goes dim.
- Turn off the switch when the luminaire is not in use.
- The efficiency may decrease if the luminaire is used or charged when temperature is below 32F (0°C) or above 104F (40°C).
- To avoid damage to the luminaire, please do not use any other than the specified battery.
- To avoid electrical shock, please do not open the luminaire unless by a qualified person.





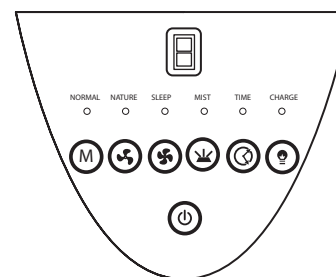

### How to recharge

- Ensure that the lamp is turned off during charging to prolong battery life.
- Make sure the voltage is correct before charging luminaire.
- Plug into the mains electrical supply. The charge indicator light will shine red to show that the luminaire is charging and turn green when fully charged.
- Fan has over charge and over discharge protection.
- Charge the lamp periodically for at least 8 hours while not in use for over 3 months to prolong the battery life.

### How to Change and assemble the water tank

- Follow the steps shown in drawing 2 on Illustration part of manual.
- Remove and install water tank as shown in Drawing 3.
- Fill the tank as shown in drawing 4.
- Turn on the unit if the mist button flashes, then the water tank needs refilling.



-  Standby / Mode, Fan turns off in 20min if no other function is used.
-  Increase Fan speed from.
-  Decrease Fan speed from.
-  Activate mist mode 1 - 3
-  Wind mode (normal / natural / sleep)
-  Timer switch 0 - 9hrs
-  LED Light on / off switch